

# HAE150U Series

## 150 Watts

- EN50155 and EN45545-2 for Rail Applications
- Ultra Wide input 10:1 (16-160V)
- IEC 62368-1 for Industrial Applications
- -40 to 105°C Operation
- Remote on/off and +10% up and -20% down Output Trim
- 3 Year warranty



The 10:1 ultra wide input HAE150U series of half brick DC/DC converters accept inputs from as little as 16V to 160V and provide outputs from 5 to 53V. The HAE150U series has both IEC62368-1, EN50155 safety and EN45545-2 approvals for rail applications. The units operate from -40 to +105°C and come complete with remote on/off function and output trim. All models have a Fidus 3 year warranty.

Dimensions:

2.4 x 2.28 x 0.51" (61 x 57.9 x 13mm)

## Models & Ratings

Model Number	Input Voltage	Output Voltage	Output Current	No Load Current	Maximum Capacitive Load	Efficiency
HAE150-72S05UA/B	16-160V	5V	30.0A	33mA	45000	90.5%
HAE150-72S12UA/B		12V	12.5A	16mA	8000	92.5%
HAE150-72S15UA/B		15V	10.0A	26mA	5000	91.5%
HAE150-72S24UA/B		24V	6.3A	30mA	2000	89.5%
HAE150-72S28UA/B		28V	5.4A	32mA	1470	89%
HAE150-72S48UA/B		48V	3.2A	23mA	470	92%
HAE150-72S53UA/B		53V	2.9A	30mA	390	91.5%

## General

Parameter	Minimum	Typical	Maximum	Units	Notes & Conditions
Efficiency	89		92.5	%	See Model & Ratings table
Isolation	3000			VDC	Input to output 60sec
	1500				Input/output to case 60sec
Isolation resistance	1			GOhm	At 500VDC
Isolation capacitance			1000	pF	
Switching frequency	207	230	253	kHz	
Power density			53.76	W/In <sup>3</sup>	
MTBF		>0.3093		Mhrs	As per MIL-HDBK-217F, 25°C GB
Weight			113	g	
Case material	Aluminium base plate with plastic case				
Base material	FR4 PCB				
Potting material	Silicone (UL94 V-0)				
Safety approvals	IEC/ EN/ UL 62368-1				
Standards	EN50155, EN45545-2				

## Notes

1. For positive enable logic add **P** or leave blank for default negative switching logic. For different pin out options choose **A** or **B** see p4.
2. Series diode or mosfet required for reverse polarity protection
3. Input fuse required: 15A fast acting, BUS line (optional) 3A fast acting
4. CBUS must always be populated with capacitance. Recommended Nippon Chemi-con KXJ 150uF/200V capacitor

## Input

Parameter	Minimum	Typical	Maximum	Units	Notes & Conditions
Input voltage range	16	72	160	VDC	
Start up voltage			16	VDC	UVLO resistor open
Shut down voltage	10	11	12	VDC	UVLO resistor open
Startup time		350		ms	For both power up and remote on off
Input transient voltage	12			VDC	100ms max
Input filter					C type
Input surge voltage			185	VDC	1sec max
Remote ON/OFF Negative logic (standard)	0 3		1.2 12	VDC	Or short for ON (ref -Vin pin) Or open for OFF (ref -Vin pin)
Remote ON/OFF Positive logic (option)	3 0		12 1.2		Or open for ON (ref -Vin pin) Or short for OFF (ref -Vin pin)
Control pin current	-0.5		0.5	mA	
Remote off input current		15		mA	

## Output

Parameter	Minimum	Typical	Maximum	Units	Notes & Conditions
Output voltage	5		53	VDC	See Model & Ratings table
Set point accuracy			±1	%	
Line regulation			±0.2	%	Low line to High line
Load regulation			±1.0	%	0 to 100% load change. ±0.5 for single and ±1.0 for dual
Output voltage adjustability	-20		+10	%	Trim and remote sense see application note.
Ripple & Noise		75		mV pk-pk	5V (20MHz BW and 22uF/25V X7R MLCC + 22uF/25V POSCAP)
		150			12V and 15V (20MHz BW and 22uF/25V X7R MLCC + 22uF/25V POSCAP)
		200			24V and 28V (20MHz BW and 4.7uF/50V X7R MLCC)
		300			48V and 53V (20MHz BW and 1uF/100V X7R MLCC)
Overvoltage protection	115		130	%Vout	Hiccup automatic recovery
Overload protection	120		150	%Iout	Hiccup automatic recovery
Short circuit protection					Continuous with automatic recovery
Transient response		250		us	For a 25% load change
Temperature coefficient	-0.02		+0.02	%/°C	
Remote sense	-10		+10	%Vout	If not used sense lines must be connected to Vout

## EMC: Emissions

	Standard	Notes & Conditions
Conducted	EN50121-3-2, EN55032 A/B	See application note
Radiated	EN50121-3-2, EN55032 A/B	See application note

## EMC: Immunity

	Standard	Criteria	Notes & Conditions
ESD	EN61000-4-2	A	Air ±8kV, Contact ±6kV
Radiated	EN61000-4-3	A	20V/m
EFT/Burst	EN61000-4-4	A	2kV External components required
Surges	EN61000-4-5	A	2kV External components required
Conducted	EN61000-4-6	A	10Vrms
Magnetic fields	EN61000-4-8	A	100A/m continuous. 1000A/m 1 sec

## Thermal Considerations

Sufficient cooling should be provided to ensure reliable operation. Sufficient cooling is monitored by measuring the temperature of the centre point on the bottom of the unit as shown. This temperature should not exceed max case temperature. Base plate should be 19"x3.5"x0.063"

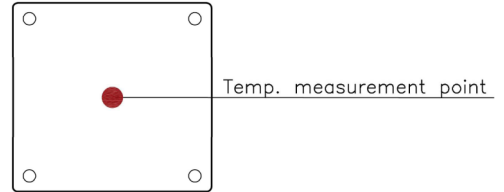

## Environmental

Parameter	Minimum	Typical	Maximum	Units	Notes & Conditions
Operating temperature	-40		105	°C	Base-plate temp. See de-rating curve
Max case temp			105	°C	
Over temp protection		110		°C	
Storage temperature	-55		125	°C	
Thermal impedance		6.1		°C/W	DC-DC module
		2.8			With base plate
Humidity	5		95	% RH	Non-condensing
Thermal shock and vibration	EN61373,MIL-STD-810F				

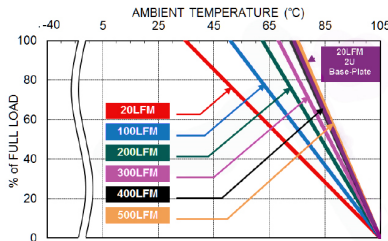

HAE150-72S12UA Derating Curve  
(See Thermal Considerations)

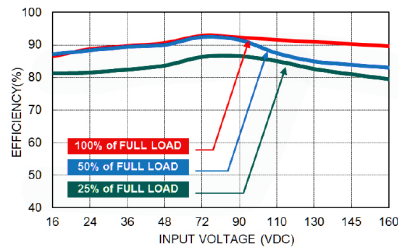

HAE150-72S12UA Efficiency vs. Input Voltage

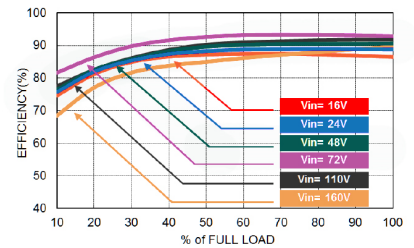

HAE150-72S12UA Efficiency vs. Output Load

## Mechanical Details

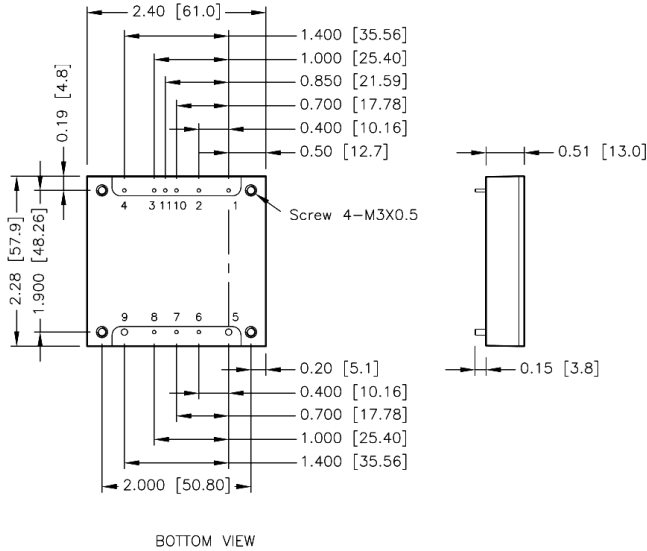

Pin	A type	B type	Diameter
1	-Vin	-Vin	0.04"
2	BUS	BUS	0.04"
3	Ctrl	UVLO	0.04"
4	+Vin	+Vin	0.04"
5	-Vout	-Vout	0.08"
6	-Sense	-Sense	0.04"
7	Trim	Trim	0.04"
8	+Sense	+Sense	0.04"
9	+Vout	+Vout	0.08"
10	UVLO	Ctrl	0.04"
11	Pulse Out	Pulse Out	0.04"

### Notes

- All dimensions shown in inches [mm]
- Tolerance 2DP ±0.02 [1DP ±0.05], 3DP ±0.010 [2DP ±0.025]
- Pin dimension tolerance ±0.004 [±0.1]
- Screw torque max 3.5kgf-cm/0.34N-m
- For best EMI performance screw all four mounting points to shield plane

## Pad layout

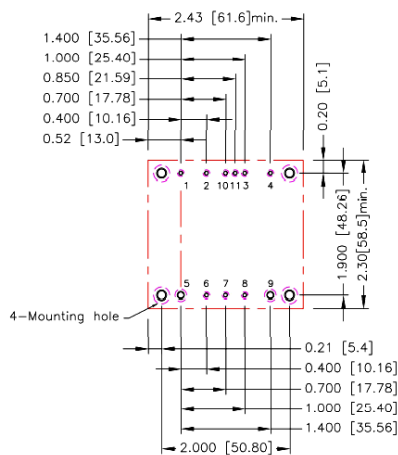

### Notes

- All dimensions shown in inches [mm]
- Through holes 1,2,3,4,6,7,8,10 & 11 Ø0.051 [1.3]
- Through holes 5 & 9 Ø0.091 [2.3]
- Mounting through holes Ø0.126 [3.2]
- Top view pad 1,2,3,4,6,7,8,10 & 11 Ø0.64 [1.63]
- Top view pad 5 & 9 Ø0.113 [2.88]
- Top view pad mounting Ø0.157 [4]
- Bottom view pad 1,2,3,4,6,7,8,10 & 11 Ø0.102 [2.6]
- Bottom view pad 5 & 9 Ø0.181 [4.6]
- Bottom view pad mounting Ø0.252 [6.4]

## Application note

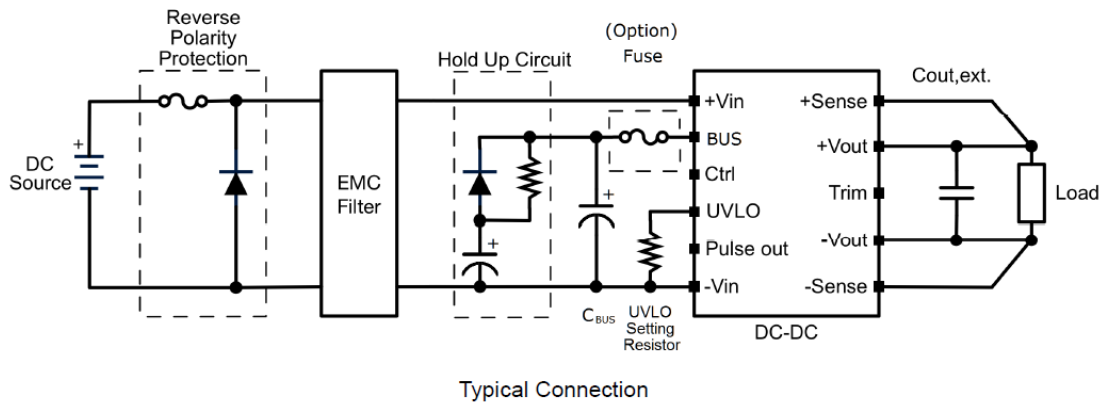

### UVLO

The ultra wide input can be tailored for added protection by implementing an under voltage lock out. Using the equation below an appropriate resistor can be implemented for the desired lock out voltage on the module's input:

$$V_{in,on} = \left( \frac{451.23}{R_{UVLO} + 3} + 15.18 \right) V \quad V_{in,off} = \left( \frac{448.5}{R_{UVLO} + 3} + 10.80 \right) V$$

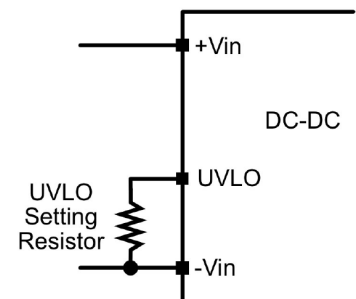

### Hold Up

The holdup of the module can be tailored by adding the desired capacitance as shown in the adjacent circuit diagram. Please contact FiDUS Power if you have a specific hold up requirement at a given load and voltage input.

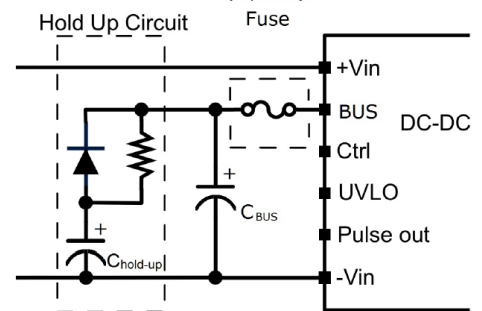

### Pulse out

This pin generates a voltage pulse with a fixed frequency. It provides the function that could achieve inrush current limit with an external circuit. If the Pulse Out pin is not to be used, please leave this pin floating.

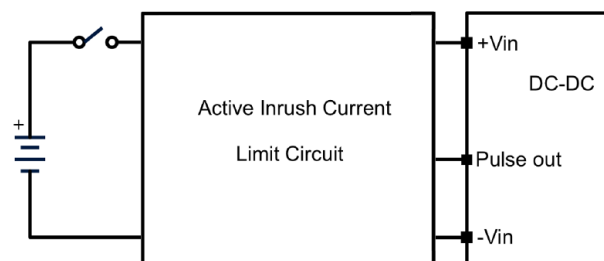

## Trim Tables

Output voltage trim function allows the user to increase or decrease the output voltage set point. The module may be connected with an external resistor (Rtrim) between TRIM pin and either +Vout or -Vout. By adjusting Rtrim, the output voltage can be changed by +10% or -20% of nominal the output voltage. Power of resistor needs to be 1/8 of rated power minimum.

Trim up equation

$$R_U = \left( \frac{V_{OUT}(100 + \Delta\%) - 100 + 2\Delta\%}{\Delta\%} \right) k\Omega$$

Trim down equation

$$R_D = \left( \frac{100}{\Delta\%} - 2 \right) k\Omega$$

Trim up (RU)

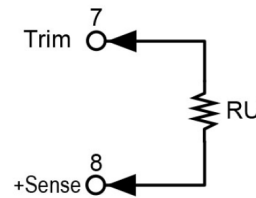

Trim Down RD

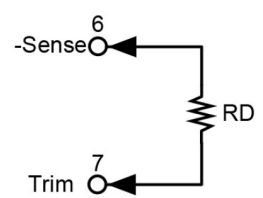

### 5V OUTPUT TRIM UP

ΔV%	1	2	3	4	5	6	7	8	9	10	%
Vout	5.05	5.10	5.15	5.20	5.25	5.30	5.35	5.40	5.45	5.50	Volts
RU	310.245	156.163	104.803	79.122	63.714	53.442	46.105	40.602	36.322	32.898	kOhms

### 12V OUTPUT TRIM UP

ΔV%	1	2	3	4	5	6	7	8	9	10	%
Vout	12.12	12.24	12.36	12.48	12.60	12.72	12.84	12.96	13.08	13.20	Volts
RU	887.388	447.592	300.993	227.694	183.714	154.395	133.452	117.745	105.528	97.755	kOhms

### 15V OUTPUT TRIM UP

ΔV%	1	2	3	4	5	6	7	8	9	10	%
Vout	15.15	15.30	15.45	15.60	15.75	15.90	16.05	16.20	16.35	16.50	Volts
RU	1134.735	572.490	385.075	291.367	235.143	197.660	170.886	150.806	135.188	122.694	kOhms

### 24V OUTPUT TRIM UP

ΔV%	1	2	3	4	5	6	7	8	9	10	%
Vout	24.24	24.48	24.72	24.96	25.20	25.44	25.68	25.92	26.16	26.40	Volts
RU	1876.776	947.184	637.320	482.388	389.429	327.456	283.190	249.990	224.168	203.510	kOhms

### 28V OUTPUT TRIM UP

ΔV%	1	2	3	4	5	6	7	8	9	10	%
Vout	28.28	28.56	28.84	29.12	29.40	29.68	29.96	30.24	30.52	30.80	Volts
RU	2206.571	1113.714	749.429	567.286	458.000	385.143	333.102	294.071	263.714	239.429	kOhms

### 48V OUTPUT TRIM UP

ΔV%	1	2	3	4	5	6	7	8	9	10	%
Vout	48.48	48.96	49.44	49.92	50.40	50.88	51.36	51.84	52.32	52.80	Volts
RU	3855.551	1946.367	1309.973	991.776	800.857	673.578	582.665	514.480	461.447	419.020	kOhms

### 53V OUTPUT TRIM UP

ΔV%	1	2	3	4	5	6	7	8	9	10	%
Vout	53.53	54.06	54.59	55.12	55.65	56.18	56.71	57.24	57.77	58.30	Volts
RU	4267.769	2154.531	1450.109	1097.898	886.571	745.6871	645.055	569.582	510.880	463.918	kOhms

### TRIM DOWN ALL VOLTAGES

ΔV%	1	2	3	4	5	6	7	8	9	10	%
RU	98	48	31.333	23	18	14.667	12.286	10.5	9.111	8	kOhms
ΔV%	11	12	13	14	15	16	17	18	19	20	%
RU	7.091	6.333	5.692	5.143	4.667	4.25	3.882	3.556	3.263	3	kOhms