

TLB6-A1SVE



Residual Current Transducer

DIMENSIONS:

From 1.047 x 0.929 x 1.114" (26.6 x 23.6 x 28.3mm)

IEC 62752 (IC-CPD)

IEC 62955 (RDC-PD)

5000A SURGE

General specifications

Part number	Input voltage	DC residual current	AC residual current	Rated current	Static power dissipation
TLB6-A1SVE	5VDC	6mA	30mA	40A	0.25W

Electrical specifications

Parameter	Symbol	Min	Typical	Max	Unit
Rated residual DC operating current	$I_{\Delta NDC}$		6		mA
Rated residual AC operating current	$I_{\Delta NAC}$		30		mA
Range of remaining DC operating current	$I_{\Delta NDC-RANGE}$	3	4.5	6	mA
Range of remaining AC operating current	$I_{\Delta NAC-RANGE}$	15	24	30	mA
Input voltage	V_{CC}	4.85	5	5.15	V
Rated current			25	50	mA

Mechanical

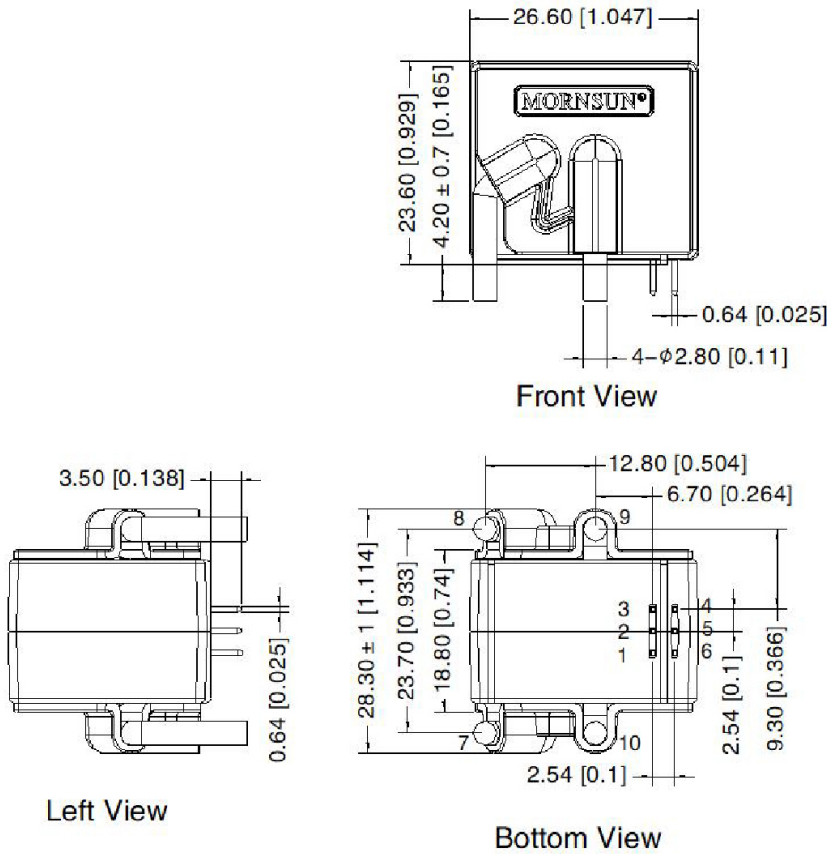

THIRD ANGLE PROJECTION

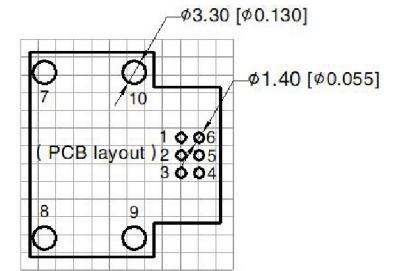

Note: Grid 2.54*2.54mm

Notes

1. All dimensions shown in mm [Inch]
2. Pin tolerance: $\pm 0.10[\pm 0.004]$
3. General tolerances $\pm 0.50[\pm 0.02]$

Pin-Out

PIN	Description
1	NC
2	Calibrate
3	Test-input
4	Vcc
5	GND
6	Trip
7-10	Primary wire connection

Pin out description

PIN	ID	Description
1	NC	Not connected
2	Calibrate	Zero calibration pin, when the pin inputs a duration >50ms and <100ms low voltage, the calibration function is enabled and the residual current detected at that moment is used as the zero current point. This residual current compensation value is stored in non volatile memory.
3	Test-input	Test pin, when high there will be a built-in residual current generated, making the trip active to self-test system.
4	Vcc	100nF and 1uF capacitors are required in parallel on input
5	GND	Ground
6	Trip	Trip output pin, when detected > 6mA DC residual current or > 30mA AC residual current, the pin is set high
7-11	-	For primary wires connection

Application notes

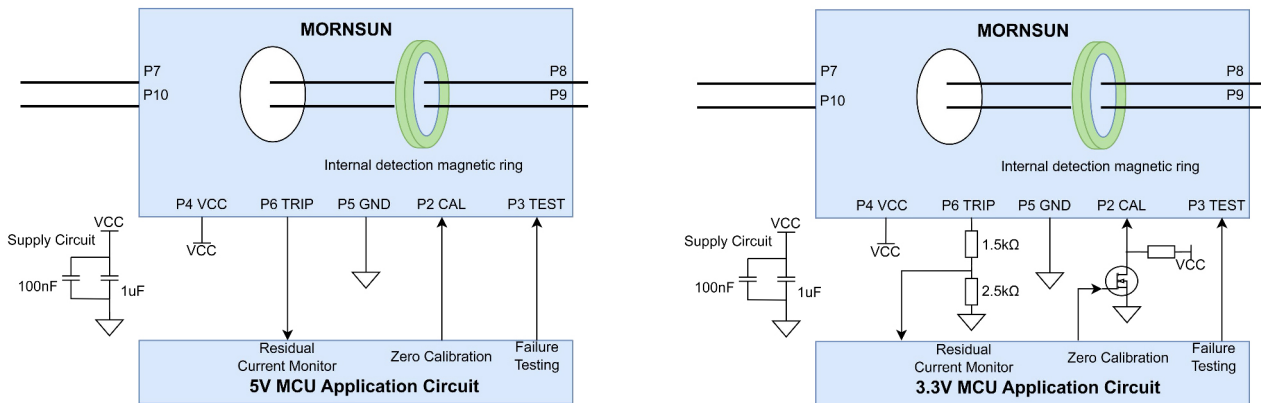

NOTES

- Two capacitors 1uF/16V and 100nF/16V need to be fitted at VCC and GND for energy storage and decoupling.
- Residual current protection monitoring pin TRIP, zero calibration pin CAL, and TEST-IN pin are generally controlled by a micro controller.
- The residual current protection detection pin will output high level when the current the trip specification value.
- When the module is started, the zero calibration pin should be kept at a low level for a period of time and then placed at a high level. See the timing sequence characteristic description
- TEST-IN is used to test the performance of residual current transducer when self-test is required, and the test signal needs to meet the timing characteristics on page 5
- Hot plug is unavailable.
- The product is connected to 5V MCU for use, and it is necessary to pay attention to level matching. If a 3.3V MCU is connected, a level conversion circuit is required for voltage conversion (as shown in the figure above). The 5V voltage is converted to 3.3V by two resistors, and the ratio of the two resistors is generally selected to be close to 3:5. At the same time, the input impedance of the MCU should be considered, and the resistance value of the two voltages should not be greater than one-tenth of the input impedance of the MCU. For example, the values of the two resistors are 1.5kΩ and 2.5kΩ or 10kΩ and 15kΩ. In addition, the zero calibration function and failure testing function need to adjust the timing. For example, the zero calibration function of the product is effective at a low level. After connecting the MOS for level conversion, the 3.3V MCU should output a high level to make the calibration function effective, and the 3.3V MCU should output a low level when the product is not calibrated. Similarly, the 3.3V MCU output low level makes the failure testing function effective; When failure testing is not in use, the 3.3V MCU should output a high level.



Performance characteristic

Parameter	Symbol	Residual current waveform	Min	Typical	Max	Unit
Residual operating current	$I_{\Delta NDC50}$	Frequency 50Hz AC	15	22.5	30	mA RMS
	$I_{\Delta NA0}$	0 Angle pulsating DC	11	15	30	mA RMS
	$I_{\Delta NA90}$	90 Angle pulsating DC	10	15	30	mA RMS
	$I_{\Delta NA135}$	135 Angle pulsating DC	10	15	35	mA RMS
	$I_{\Delta NS-DC}$	Smooth DC	3	4.5	6	mA RMS
	$I_{\Delta N2-PDC}$	Two phase rectification DC	3.5	5	7	mA RMS
	$I_{\Delta N3-PDC}$	Three phase rectification DC	3.1	4.5	6.2	mA RMS
	$I_{\Delta NF}$	Composite current	18	28	38	mA RMS
Response time	$T_{\Delta NAC50@30mA}$	RMS 30mA Frequency 50Hz AC		40	60	mS
	$T_{\Delta NAC50@60mA}$	RMS 60mA Frequency 50Hz AC		30	60	mS
	$T_{\Delta NAC50@150mA}$	RMS 150mA Frequency 50Hz AC		15	40	mS
	$T_{\Delta NA0@42mA}$	RMS 42mA 0 Angle pulsating DC		38	50	mS
	$T_{\Delta NA0@84mA}$	RMS 84mA 0 Angle pulsating DC		30	40	mS
	$T_{\Delta NA0@210mA}$	RMS 210mA 0 Angle pulsating DC		25	35	mS
	$T_{\Delta NA0@42mA+S-DC@6mA}$	RMS 42mA 0 Angle pulsating DC + 6mA smooth DC		38	50	mS
	$T_{\Delta NA0@84mA+S-DC@6mA}$	RMS 84mA 0 Angle pulsating DC + 6mA smooth DC		30	40	mS
	$T_{\Delta NA0@210mA+S-DC@6mA}$	RMS 210mA 0 Angle pulsating DC + 6mA smooth DC		25	35	mS
	$T_{\Delta NS-DC@6mA}$	6mA smooth DC		140	200	mS
	$T_{\Delta NS-DC@60mA}$	60mA smooth DC		25	60	mS
	$T_{\Delta NS-DC@300mA}$	300mA smooth DC		25	30	mS
	$T_{\Delta N2PDC@6mA}$	RMS 6mA two phase rectification DC		140	200	mS
	$T_{\Delta N2PDC@60mA}$	RMS 60mA two phase rectification DC		25	60	mS
	$T_{\Delta N2PDC@300mA}$	RMS 300mA two phase rectification DC		25	30	mS
	$T_{\Delta N3PDC@6mA}$	RMS 6mA three phase rectification DC		140	200	mS
	$T_{\Delta N3PDC@60mA}$	RMS 60mA three phase rectification DC		25	60	mS
	$T_{\Delta N3PDC@300mA}$	RMS 300mA three phase rectification DC		25	30	mS
	$T_{\Delta NF@210mA}$	RMS 210mA composite current		15	35	mS

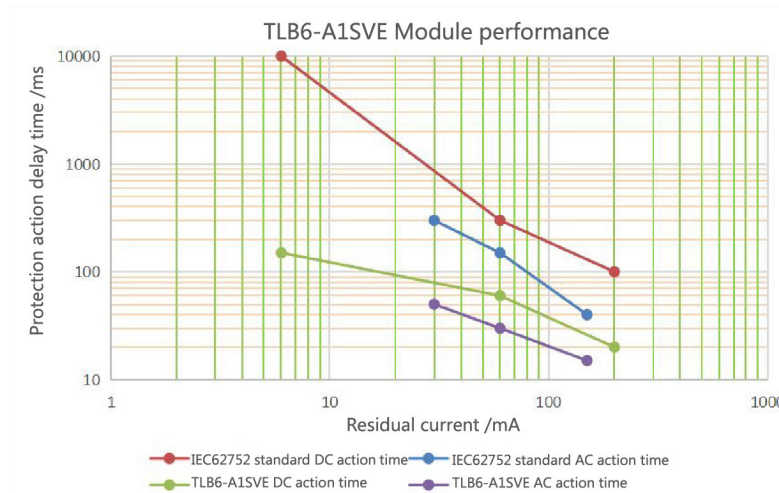

Timing characteristic

Parameter	Symbol	Min	Typical	Max	Unit
Start To Calibration Interval	T1	600			mS
Calibrate Signal Maintenance Time	T2	50		100	mS
Calibration Signal Completion Wait Time	T3		500		mS
Test Signal Duration	T4			200	mS

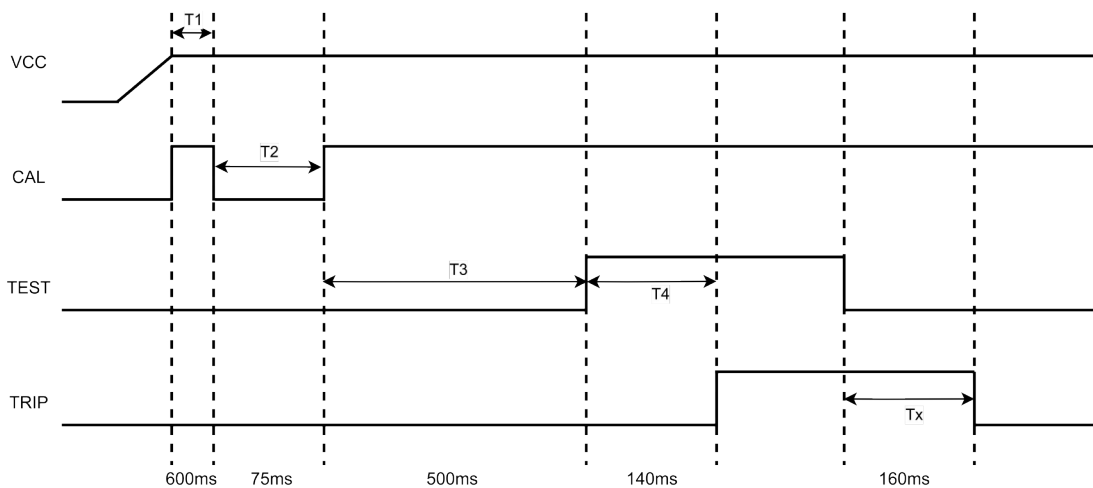

Timing application design essentials:

1. After the power supply is fully started, the startup and stabilization time of the module is about 200-300ms. The zero calibration delay time T1 should be greater than 100ms.
2. The zero calibration signal duration T2 should be greater than 50ms and less than 100ms; When the CAL low time is greater than 50ms, TLB6-ASVE starts to zero calibration.
3. The waiting time T3 for calibration completion should be greater than 500ms.
4. TEST-IN self-test signal can only be enabled after T3 is completed. After TEST-IN signal is applied and between 100-140ms (T4), TRIP is set to high.
5. After TRIP is set to high, TEST-IN can be set to low at any time, turn off the TEST-IN signal and then after Tx=150-250ms, TRIP pin high level returns to low level

Protection and detection specifications

Parameter	Symbol	Min	Typical	Max	Unit
Self Check Input Low Level Voltage	$V_{TEST-INIL}$	0		1	V
Self Check Input High Level Voltage	$V_{TEST-INIH}$	3		5.1	V
Calibration Input Low Voltage	V_{CAL-IL}	0		1	V
Calibration Input High Voltage	V_{CAL-IH}	4		5.1	V
Operating Output Low Level Voltage	$V_{TRIP-OL}$	0		0.6	V
Operating Output High Level Voltage	$V_{TRIP-OH}$	4.5		5.15	V

General specifications

Parameter	Symbol	Min	Typical	Max	Unit
Operating temperature	T_A	-40		85	°C
Storage temperature	T_s	-40		125	°C
Weight	m	14	17	20	g
Vibration	0-150Hz, 5g (GB2423.10, IEC60068-2-6)				
Over voltage category	OVC III (IEC61010)				

Isolation specifications

Parameter	Operating conditions	Min	Typical	Max	Unit
Isolation voltage	Primary to secondary 50hz 1min. Leakage current <0.1mA			3	kVAC
Insulation Resistance	500VDC	1			GΩ
Pulse withstand voltage	1.2/50μs		7		kV

EMC specifications

Parameter	Operating conditions	Specifications	Performance
EMI	Conducted and Radiated	CISPR32/EN55032	Level B
EMS	ESD EN61000-4-2	Contact ±6kV, Air ±8KV	A
	RS EN61000-4-3	30V/m	A
	Surge current	6000V/2Ω/3000A, 8/20us	B